

SHANTUI

SE20

Mini Crawler Excavator



Engine model: Kubota D902
Engine power: 11.8kW/2300rpm
Operating weight: 2000kg
Bucket capacity: 0.04m³

VALUE THAT WORKS

SE20 TECHNICAL PARAMETERS

ENGINE

Model	Kubota D902
Type	Three-cylinder direct injection
No. of cylinders	3
Emission standard	Tier 4 and Euro 5
Displacement	0.989L
Rated power	11.8kW/2300rpm

HYDRAULIC SYSTEM

Type	Variable plunger pump
Rated operating flow	64.4L/min

DIGGING FORCE (ISO6015)

Bucket digging force	16kN
Arm digging force	9.5kN

BUCKET

Type	Digging bucket
Bucket capacity	0.04m ³
Bucket width	450mm

TRAVEL SYSTEM

Type	Plunger motor
Number of track rollers	3X2
Number of carrier rollers	/
Number of track shoes	37X2
Travel speed	2.4/4.2km/h
Traction force	18kN
Gradeability	30%

SWING SYSTEM

Swing motor	NACHI
Swing speed	0~10r/min
Brake type	Mechanical braking

FUEL TANK CAPACITY (L)

Fuel tank capacity	23
Cooling system	5
Engine oil	3.7
Hydraulic oil tank	17
System capacity	25

OPERATING WEIGHT AND GROUND PRESSURE

Ground pressure	30kPa
Operating weight	2000kg

OPERATING RANGE(MM) (Boom: 1828 mm Arm: 950 mm)

A Max. digging height	3535
B Max. dumping height	2445
C Max. digging depth	2270
D Max. vertical digging depth	1910
E Max. digging depth cut for 2500mm level bottom	1520
F Max. digging distance	3925
G Max. digging distance at ground level	3860
H Maximum lifting height of bulldozer blade	230
I The maximum cutting depth of the dozer blade	235

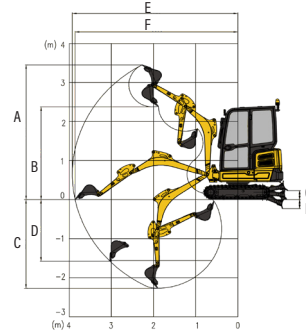

OVERALL DIMENSION (MM)

A Overall length	3845
B Ground contact length (Transportation)	2460
C Overall height (to top of boom)	1105
D Overall width	990/1300
E Overall height (to top of cab)	2400
F Ground clearance of counterweight	460
G Min. ground clearance	145
H Tail swing radius	1070
I Tread	1230
J Track length	1593
K Track gauge	760/1070
L Track width	990/1300
M Shoe width	230
O Bonnet height	-
P Revolving frame width	990
Q Distance from swivel center to tail	1070

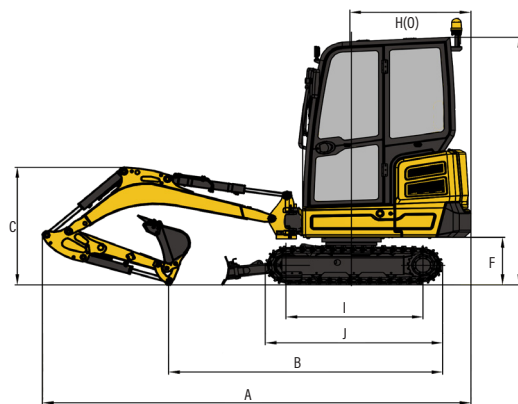
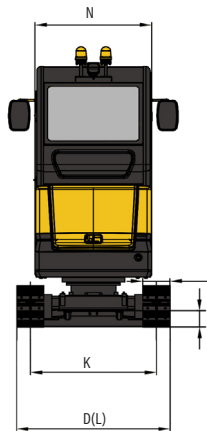

* THE SPECIFICATIONS ARE SUBJECT TO CHANGE WITHOUT NOTICE. THE PICTURES MAY INCLUDE OPTIONAL CONFIGURATION. THE ACTUAL COLOR & APPEARANCE OF THE PRODUCT MAY DIFFER FROM WHAT IS SHOWN.



Shantui Social

SHANTUI CONSTRUCTION MACHINERY CO., LTD.

ADD: NO. 58, G327 HIGHWAY, HI-TECH ZONE, JINING CITY, SHANDONG, CHINA

TEL: +86-537-2909369 FAX: +86-537-2311219

EMAIL: trade@shantui.com WEB: www.shantui.com

SHANTUI
VALUE THAT WORKS